

VMU Series

VENTURI MIXING UNIT FOR VR400Vx/ VR800Vx GAS CONTROLS

PRODUCT HANDBOOK



APPLICATION

The venturi mixing unit combined with the VR4xxVx / VR8xxVx gas valve and specific EC-fan, has been developed for modulating premix appliances like gas burners, gas boilers etc..

Note: The information of this handbook supplements those of the Product Handbook

- EN1C-0047 of the VR400/VR800 Series, class „A“ servo regulated combination valves
- EN2R-9017 of the 45.801.190-, 1:1 gas/air regulator assembly gas controls

EN1C-0047 is important to choose a suitable valve and EN2R-9017 shows the characteristics of the 1:1 regulator on the valve

CONTENTS

GENERAL

Description	2
Features	2

TECHNICAL DATA

Specifications	2
Dimensional drawing of the system (VMU150 - VMU400)	3
Dimensional drawing venturi manifold (VMU150 - VMU400)	3
Dimensional drawing of the system (VMU500 - VMU680)	4
Dimensional drawing venturi manifold (VMU500 - VMU680)	4
Adjustments and final checkout	5

VARIOUS

Standards and approvals	5
Application notes	5
Ordering information	6

DESCRIPTION

The venturi manifold is a gas/air mixing unit that allows modulation of a premix burner with constant gas/air ratio down to 17% of maximum load. It is to be used in combination with a fan and Honeywell 1:1 regulation gas valve.

The modulation is accomplished by changing the fan speed.

The throttle to adjust the gas/air ratio is integrated in the valve.

The outlet pressure of the gas valve is regulated to ambient pressure by the gas valve.

In this documentation, it is assumed that the fan is mounted downstream of the venturi.

The venturi generates a negative pressure against ambient by which the gas is drawn through the gas valve outlet.

The venturi manifold system is designed to be fitted in up to 6 positions on an EC fan (typically an EBM fan G1G170 for the venturis VMU 150 to VMU 400 and EBM fan G3G250 for VMU 500 to VMU 680), using 6 bolts M8.

The venturi manifold is sealed with an O-ring to the fan. The O-ring is already mounted in the venturi assembly.

The VR400Vx / VR800Vx HONEYWELL gas valve can be fitted directly on the manifold assembly in up to 3 positions.

All regulation adjustments are made on the gasvalve (for example throttle function (screw) for adjustment on gas type and for trimming to the correct gas/air ratio).

To ensure constant gas/air ratio and safe function under all circumstances, a connection tube between the inlet of the venturi manifold and the gas pressure regulator is provided. This compensation tube is required to ensure a safe function in case of a blocked air inlet.

FEATURES

General

- All adjustments and test points from one (top) side accessible.
- Wide modulation band (17....100% boiler load) possible.
- Flexible mounting positions of gas control to venturi manifold and venturi manifold to fan.
- Lower fan speed, power consumption and noise level at normal modulation range (25 100% boiler load) possible.

SPECIFICATIONS

Model

Model	Reference load
VMU 150A xxxx	150 kW
VMU 185A xxxx	185 kW
VMU 300A xxxx	300 kW
VMU 335A xxxx	335 kW
VMU 400A xxxx	400 kW
VMU 500A xxxx	500 kW
VMU 680A xxxx	680 kW*

*) on customer demand

Dimension

See dimensional drawing on page 3+4

Ambient temperature

0 °C 100 °C

Gas valve connection

Four M5 screws and a NBR O-ring are provided with the venturi to assemble it to the Honeywell VR400 gas valve. The plastic tube provided with the venturi has to be connected between the venturi inlet (fast connectors assembled) and the 1:1 pressure regulator on the gas valve.

Fan connection

The venturi is connected to the fan using 6 M8 bolts (provided).

Minimum load

The minimum load for which the unit can be used is 17% of the reference load, which equals a minimum signal pressure of 50 Pa to the 1:1 gas control.

This signal pressure can be measured between the connection venturi manifold – pressure regulator and the pressure taps on the small flange on the venturi, where the valve is fixed. To measure it, the application has to be operated at its minimum modulation level.

The recommended minimum of this signal pressure is 50 Pa at minimum load and opened valve. The absolute minimum is 42 Pa at opened respectively 50 Pa at closed valve.

Venturi (negative) pressure

1700 Pa minimum at reference load and 8.7% CO₂ (pressure tap on small flange on the venturi, where valve is fixed).

Material

Housing: Aluminium

Venturi: statically dissipative statcon PF

Seals: rubber (NBR)

Pressure drop

900 Pa maximum across the venturi at reference load

Tracking accuracy

Typical 3-6% of the adjusted CO₂ - Level

DIMENSIONAL DRAWING OF THE SYSTEM (VMU150-VMU400)

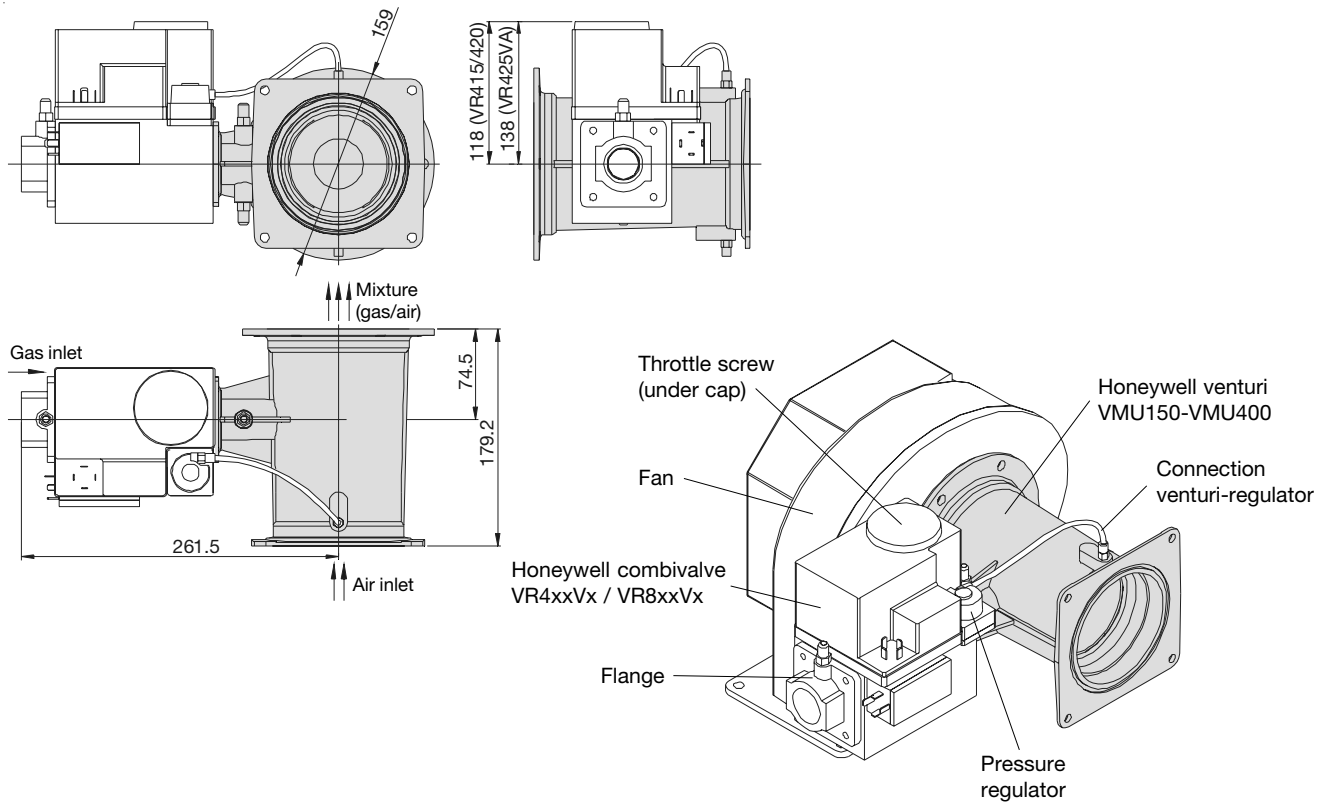

DIMENSIONAL DRAWING VERTURI MANIFOLD (VMU150-VMU400)

(Tolerances: ISO 2768-mH)

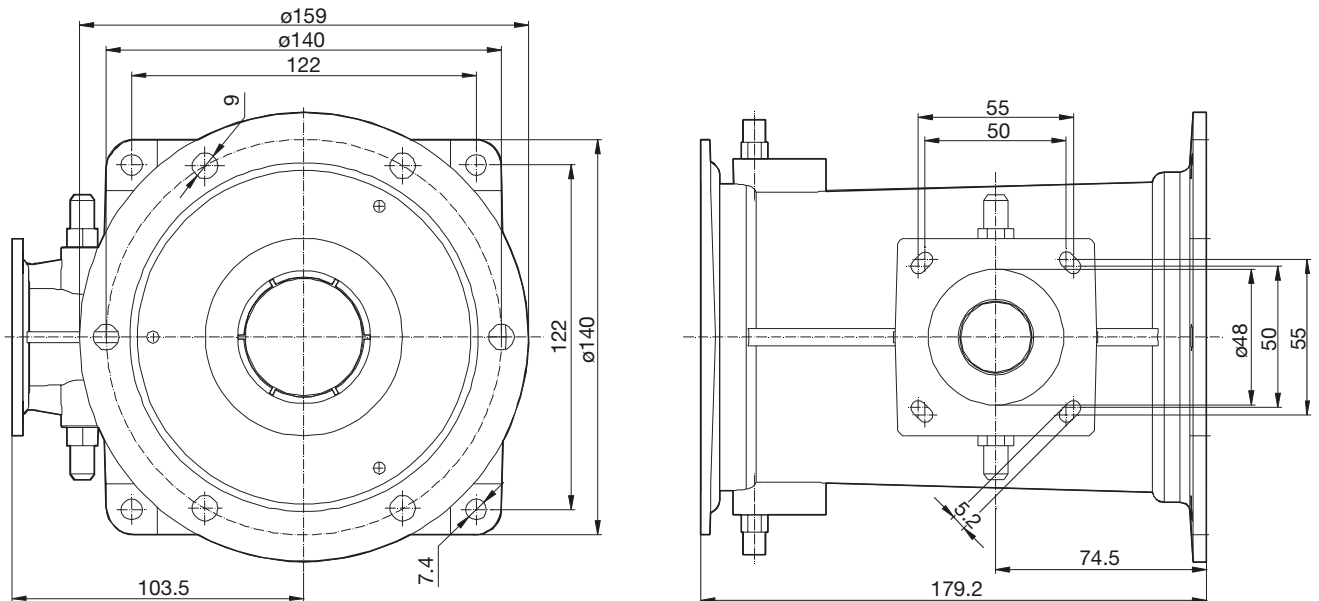

DIMENSIONAL DRAWING OF THE SYSTEM (VMU500-VMU680)

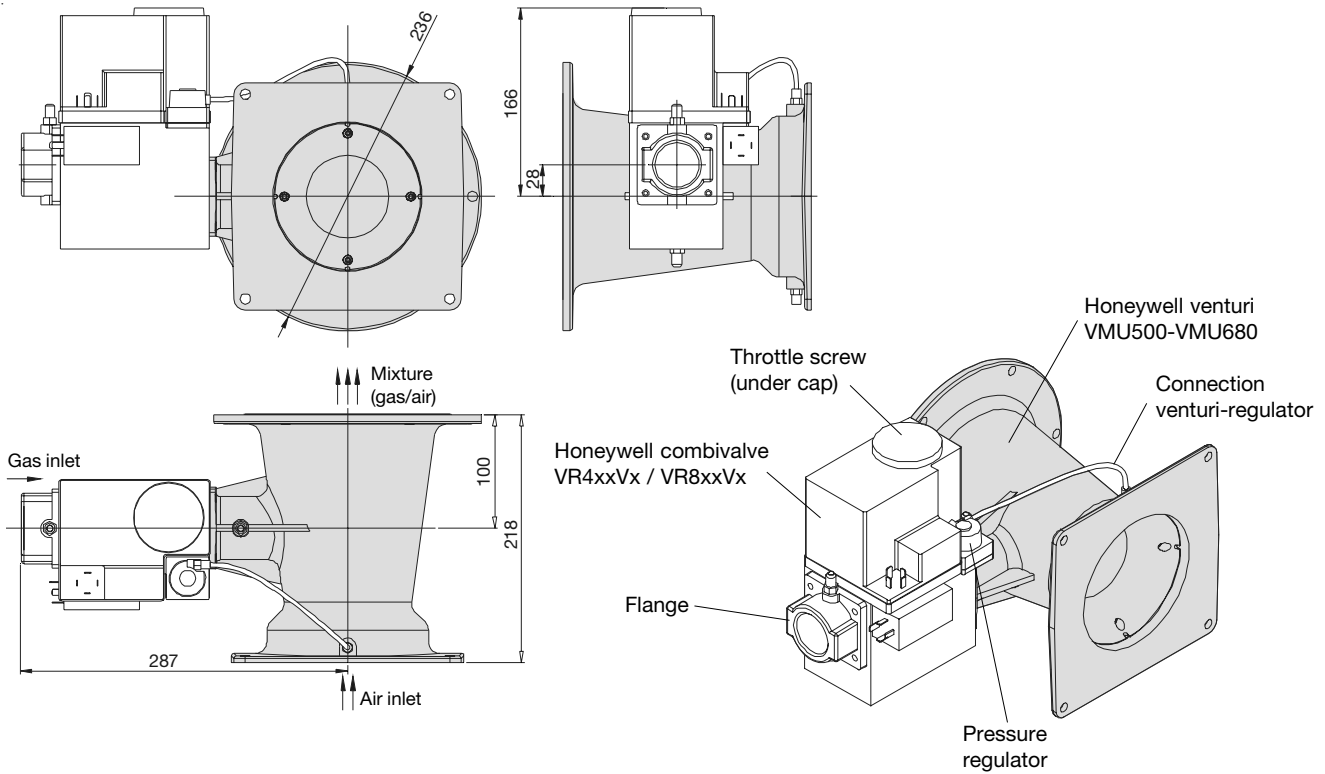

DIMENSIONAL DRAWING VERNTURI MANIFOLD (VMU500-VMU680)

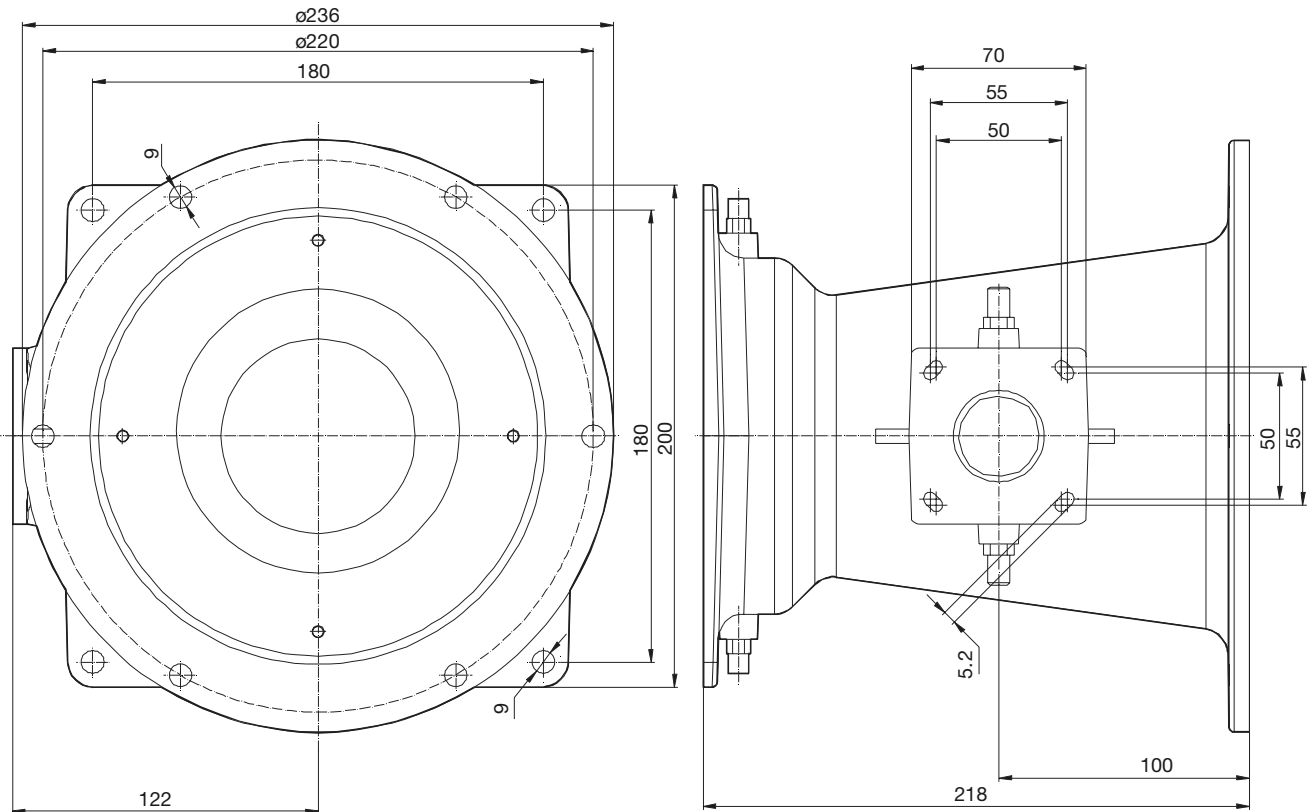

ADJUSTMENTS AND CHECKOUT

Note: All adjustments are made on the gas valve and not on the venturi

Adjustment

- Check gas input to the appliance using a pressure gauge.
 - Put CO₂ meter probe (inaccuracy < 0.1%) into exhaust gas outlet.
 - Screw throttle adjustment screw approx. half way down (about 3,5 mm turned down).
- 1 Start appliance
 - 2 Run appliance at maximum load.
 - 3 Observe CO₂ meter and adjust throttle screw until CO₂ percentage is at nominal value.
Turn throttle screw clockwise to reduce gas flow and CO₂ percentage.
 - 4 If appliance does not start, turn throttle screw 1/2 turns counter clockwise and repeat starting procedure.
 - 5 Keep appliance running until completely stabilised, modify adjustment when necessary.
 - 6 Set appliance to minimum load according to the manufacturer's instructions.
 - 7 Observe CO₂ meter and adjust regulator screw until CO₂ percentage is at nominal value at minimum load.
Turn regulator screw anticlockwise to reduce gas flow and CO₂ percentage.
- Repeat from 1 to 6 inclusive when adjustment of offset pressure is necessary.

After adjustments are made, stop appliance, disconnect pressure gauge and CO₂ meter and tighten the pressure taps.

Final checkout of the installation

After any adjustment, set appliance in operation. Observe several complete cycles to ensure that all burner components function correctly.

STANDARDS AND APPROVALS

The ventury manifold is not certified separately. It will be certified as part of the appliance.

APPLICATION NOTES

- Make sure the venturi inlet is not obstructed. This will influence the air factor, if the connection between the inlet of the venturi and the pressure regulator on the gasvalve is not made.
If the distance from another boiler component to the venturi inlet is more than 100 mm, air factor and boiler load are not influenced.
- There is a strong interaction between the venturi, gas control and burner. For this reason it is important to fit the characteristics of these components to each other. If not matched well, for instance acoustic problems could be generated.

It is recommended to test the appliance at both cold start and hot start conditions with high and low calorific test gases.

ORDERING INFORMATION

Legenda:

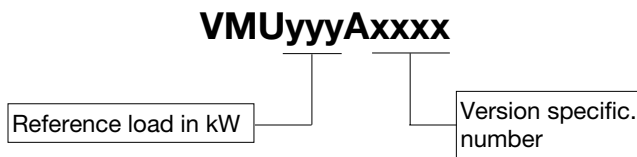

Only the ordering specification numbers for the standard types are listed here. On demand other versions xxxx are possible.

Ordering specification number	Description
VMU 150A 1003	150 kW venturi
VMU 185A 1009	185 kW venturi
VMU 300A 1004	300 kW venturi
VMU 335A 1000	335 kW venturi
VMU 400A 1010	400 kW venturi
VMU 500A 1009	500 kW venturi
VMU 680A xxxx	680 kW venturi*
KTSERV 1	accessories kit

*) on customer demand

The venturi is delivered with bolts and O'ring to connect it to the VR400Vx / VR800Vx gas valve as well as with the plastic tube that has to be connected between the venturi and gas valve.

The kit that contains these accessories (KTSERVF1) can also be ordered separately.

VMU150 to VMU400 fits onto the G1G170 fan of manufacturer EBM

VMU500 to VMU680 fits onto the G3G250 fan of manufacturer EBM

Honeywell

Automation & Control Solutions

Environmental and Combustion Controls

Satronic AG

Honeywell-Platz 1

CH-8157 Dielsdorf

Phone: +41 1 855 22 11

Fax: +41 1 855 22 22